

XG0607DC

Scissor Lift-Electric

Item	Metric
Dimension	
Overall length (without ladder/outriggers)	1450(1290)mm
Overall width	760mm
Overall height (platform folded)	2020(1660)mm
Platform length	1290mm
Platform width	700mm
Subplatform extension length	600mm
Guardrail height	1119.5mm
Toeboard height	150mm
Wheelbase	1030mm
Min. ground clearance (pothole protection deployed/undeployed)	15mm/65mm

Performance	
Max. working height (indoor/outdoor)	5.9m/0m
Max. platform height (indoor/outdoor)	3.9m/0m
Min. platform height	0.9m
Max. driving height	3.9m
Rated load	240kg
Subplatform rated load	100kg
Max. number of occupants (indoor/outdoor)	2/0
Max. driving speed (stowed)	4km/h
Max. driving speed (raised)	0.5km/h
Max. gradeability	25%
Min. turning radius (inside)	0.4m
Min. turning radius (outside)	1.55m
Platform raising time	27-37s
Platform lowering time	23-33s
Max. working slope (side to side/front and rear)	1.5°/3°

Power source	
Battery voltage	24V
Battery capacity (3HR)	80Ah
Battery charger	24V/15A
Traveling motor	0.45kW/24V
Lifting motor	1.3kW/24V
Hydraulic tank capacity	4L

Tire	
Tire size	254mm×76mm
Tire ground pressure	6.23 kg/cm ²
Driving wheels	2
Braking wheels	2
Steering wheels	2

Weight	
Total weight	900kg

Stowed

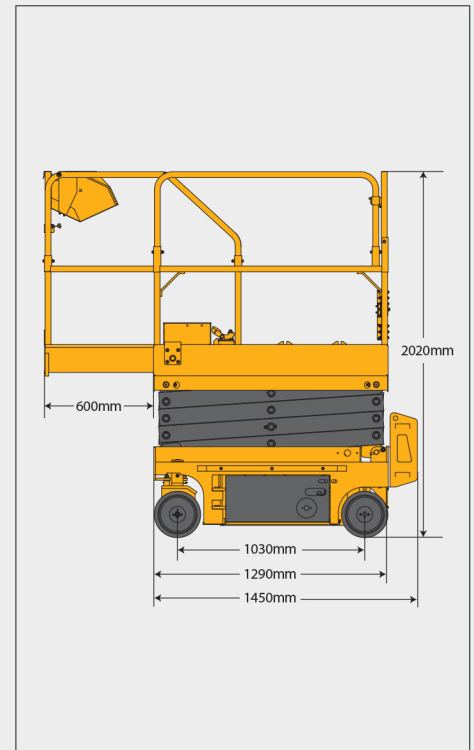

Trans

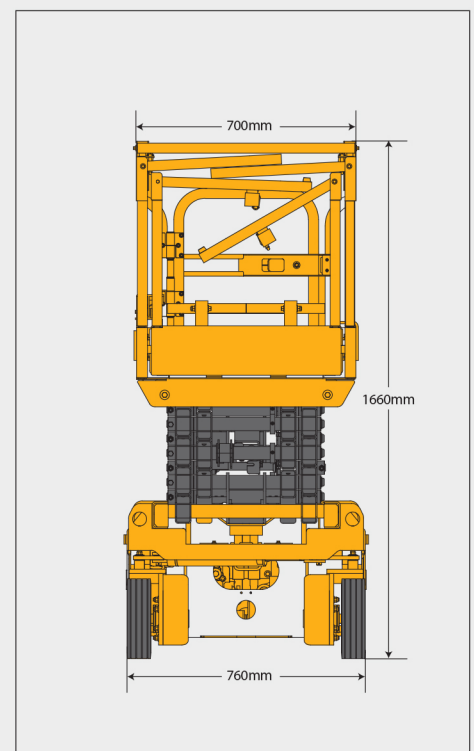

SCISSOR LIFT XG0607DC

Comply with CE

Standard configuration

- Withdrawable extension platform with position lock
- Lanyard connection point
- Self-locking half-height revolving door and folding guardrail
- Rear-wheel drive
- Travel driven by DC motor
- Full proportion travel and lift control
- 25 % gradeability
- DC maintenance-free battery
- Lubrication-free bearing
- Rotating-type component tray
- Brake release for towing
- Emergency stop device of platform and ground control
- Anti-slipping metal platform
- Weighing alarm
- Lowering alarm
- 3-second pause for lowering
- Multi-axis tilt sensor
- Multi-disc brake
- Boom maintenance lock
- Auto brake system
- Pothole protection device
- Random fault diagnosis system
- Electric horn
- High-altitude automatic low speed protection
- Charging protection system
- Detachable superstructure controller
- Intelligent charger
- Hourmeter
- Longitudinal forklift transport hole
- Flashing indicator light
- Humanized control system
- Platform control with battery level display
- Manual platform lowering valve
- Tilt sensor and audio alarm

Optional configuration

- Platform searchlight
- Platform external power supply
- Air pipe
- Platform fire extinguisher
- Platform anti-collision device
- Platform foot pedal
- Boom end cover
- PCU protective support



Working height
5.9 meters



Lift capacity
240Kg



Electric
power





MG PLANT & MACHINERY
EXPORTS & SALES LTD

CALL SALES

094 9251209

087 2466111

087 6685466