

XG1008AC

Scissor Lift-Electric

Item	Metric
Dimension	
Overall length (without ladder/outriggers)	2477(2280)mm
Overall width	810mm
Overall height (platform folded)	2350(1985)mm
Platform length	2280mm
Platform width	810mm
Subplatform extension length	900mm
Guardrail height	1135mm
Toeboard height	150mm
Wheelbase	1877mm
Min. ground clearance (pothole protection deployed/undeployed)	20mm/100mm

Performance	
Max. working height (indoor/outdoor)	10m/7.5m
Max. platform height (indoor/outdoor)	8m/5.5m
Min. platform height	1.2m
Max. driving height	8m
Rated load	230kg
Subplatform rated load	115kg
Max. number of occupants (indoor/outdoor)	2/1
Max. driving speed (stowed)	4km/h
Max. driving speed (raised)	0.8km/h
Max. gradeability	25%
Min. turning radius (inside)	0m
Min. turning radius (outside)	2.3m
Platform raising time	29-40s
Platform lowering time	35-45s
Max. working slope (side to side/front and rear)	1.5°/3°

Power source	Maintenance-free lead-acid	Lithium
Battery voltage	24V	25.76V
Battery capacity (3HR)	200Ah	202Ah
Battery charger	24V/30A	24V/36A
Traveling motor	0.87/24kW/V	
Lifting motor	3.3/24kW/V	
Hydraulic tank capacity	14L	

Tire	
Tire size	381mm×127mm
Tire ground pressure	6.23kg/cm ²
Driving wheels	2
Braking wheels	2
Steering wheels	2

Weight	
Total weight	2260kg

Stowed

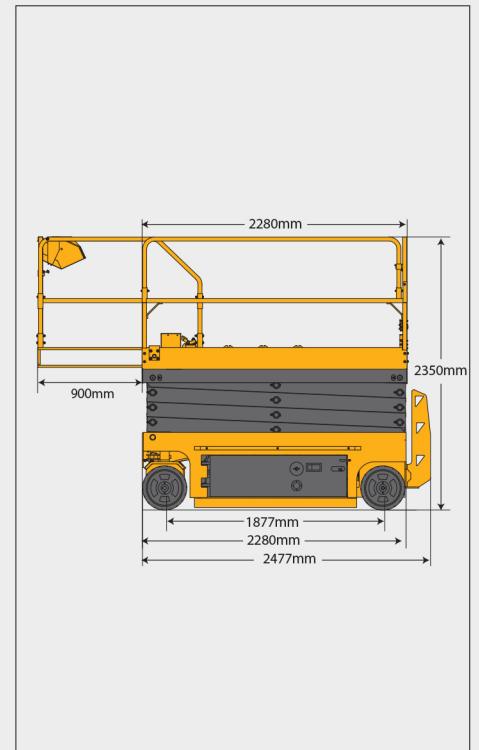

Trans

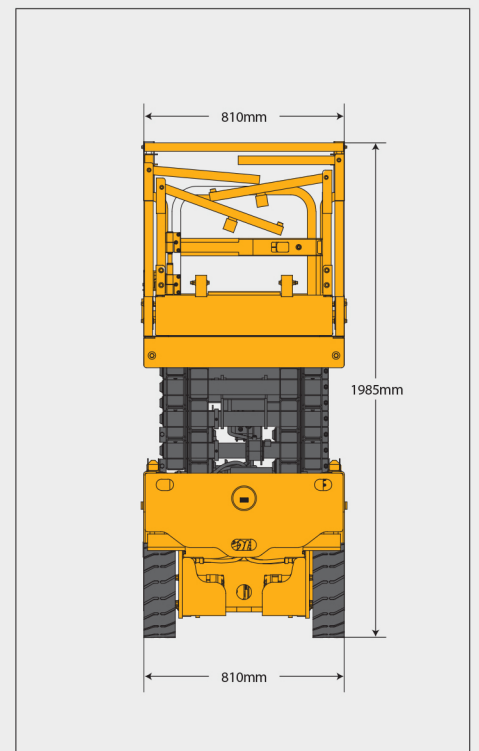

SCISSOR LIFT XG1008AC

Comply with CE

Standard configuration

- Withdrawable extension platform with position lock
- Lanyard connection point
- Self-locking half-height revolving door and folding guardrail
- Front-wheel drive
- Travel driven by AC motor
- Full proportion travel and lift control
- 25 % gradeability
- DC maintenance-free battery/Lithium battery
- Lubrication-free bearing
- Rotating-type component tray
- Brake release for towing
- Emergency stop device of platform and ground control
- Anti-slipping metal platform
- Weighing alarm
- Lowering alarm
- 3-second pause for lowering
- Multi-axis tilt sensor
- Multi-disc brake
- Boom maintenance lock
- Auto brake system
- Pothole protection device
- Random fault diagnosis system
- Electric horn
- High-altitude automatic low speed protection
- Charging protection system
- Detachable superstructure controller
- Intelligent charger
- Hourmeter
- Longitudinal forklift transport hole
- Flashing indicator light
- Humanized control system
- Platform control with battery level display
- Manual platform lowering valve
- Tilt sensor and audio alarm

Optional configuration

- Platform searchlight
- Platform external power supply
- Air pipe
- Platform fire extinguisher
- Platform anti-collision device
- Platform foot pedal
- Boom end cover
- PCU protective support



Working height
10/7.5 meters



Lift capacity
230Kg



Electric power





MG PLANT & MACHINERY
EXPORTS & SALES LTD

CALL SALES

094 9251209

087 2466111

087 6685466