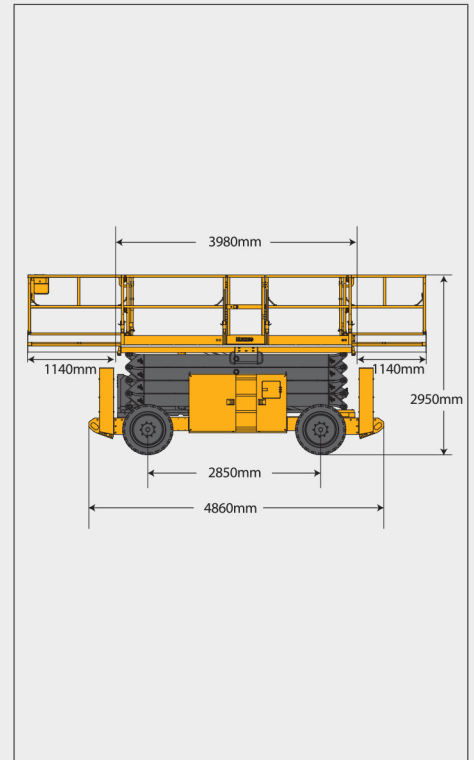
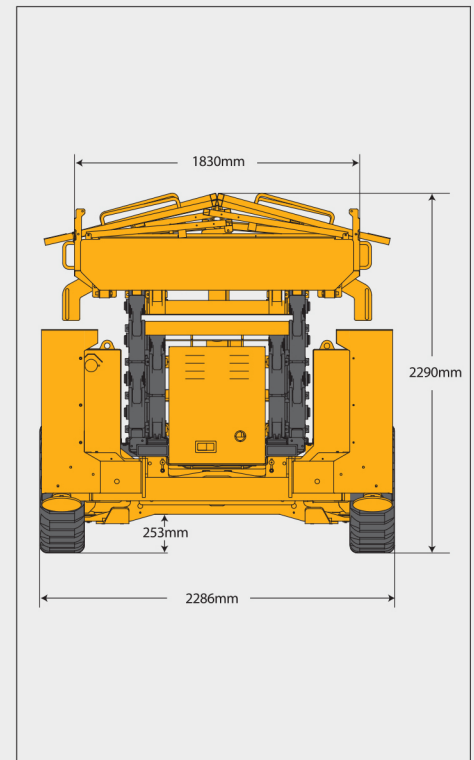

# XG1523ERT

**SOLID  
TO SUCCEED**

## Rough Terrain Scissor Lift-Electric

| Item   | Metric                               |
|--|--------------------------------------|
| <b>Dimension</b>   |                                      |
| Overall length (without ladder/outriggers)                     | 4860mm(-)                            |
| Overall width  | 2286mm                               |
| Overall height (platform folded)                               | 2950(2290)mm                         |
| Platform length  | 3980mm                               |
| Platform width   | 1830mm                               |
| Subplatform extension length                                   | 1450mm/1140mm                        |
| Guardrail height   | 1100mm                               |
| Toeboard height  | 150mm                                |
| Outrigger span (side to side/front and rear)                   | 1995mm/4280mm                        |
| Wheelbase  | 2850mm                               |
| Min. ground clearance (pothole protection deployed/undeployed) | 253mm(-)                             |
| <b>Performance</b>   |                                      |
| Max. working height  | 15m                                  |
| Max. platform height   | 13m                                  |
| Min. platform height   | 1.8m                                 |
| Max. driving height  | 3m(Standard)<br>13m(optional)        |
| Rated load   | 700kg                                |
| Subplatform rated load   | 230kg                                |
| Max. number of occupants (indoor/outdoor)                      | 7/7                                  |
| Max. driving speed (stowed)                                    | 5.1km/h                              |
| Max. driving speed (raised)                                    | 0km/h(Standard)<br>1.1km/h(optional) |
| Max. gradeability  | 40%                                  |
| Min. turning radius (inside)                                   | 2.5m                                 |
| Min. turning radius (outside)                                  | 5.6m                                 |
| Platform raising time  | 65s                                  |
| Platform lowering time   | 45s                                  |
| Max. working slope (side to side/front and rear)               | 2°/3°                                |
| Outrigger leveling angle (side to side/front and rear)         | /                                    |
| <b>Power source</b>  |                                      |
| Battery voltage  | 48V                                  |
| Battery capacity (5HR)   | 480Ah                                |
| Battery charger  | 48V/35A                              |
| Traveling motor  | 3.3kW/32V                            |
| Lifting motor  | 12kW/31V                             |
| Hydraulic tank capacity  | 100L                                 |
| <b>Tire</b>  |                                      |
| Tire size  | 835mm×290mm                          |
| Tire ground pressure   | 13.3kg/cm <sup>2</sup>               |
| Driving wheels   | 4                                    |
| Braking wheels   | 4                                    |
| Steering wheels  | 2                                    |
| <b>Weight</b>  |                                      |
| Total weight   | 7640kg                               |

**Stowed**

**Trans**

# ROUGH TERRAIN SCISSOR LIFT XG1523ERT

Comply with CE

## Standard configuration

- Foldable guardrail
- Platform self-locking door
- Dual slide-out platform extension deck
- Anti-slipping metal platform
- Boom safety maintenance support
- Pull-out engine tray
- Standard Forklift pocket for transport
- Lanyard connection point
- Fixing and lifting points
- 4-wheel drive
- Front-wheel steering
- Movement alarm
- Strobe light
- Electric horn
- Emergency stop button
- Battery power display
- Full proportion travel and lift control
- High-altitude automatic limit travel protection
- Limiting position deceleration and limit protection
- Outrigger leveling system
- Tilt protection system
- Charging protection system
- Auto brake system
- Fault diagnosis system
- Emergency lowering system
- Leveling outrigger support detection system
- Wheel-side traveling motor state monitoring and overtemperature stall protection system
- Weighing alarm system
- Axle oscillation system

## Optional configuration

- High-altitude low speed travel
- Chassis protective fence
- Non-marking rubber tire
- Platform anti-collision



Working height  
15 meters



Lift capacity  
700Kg



Electric  
power





**MG** PLANT & MACHINERY  
EXPORTS & SALES LTD

**CALL SALES**

**094 9251209**

**087 2466111**

**087 6685466**