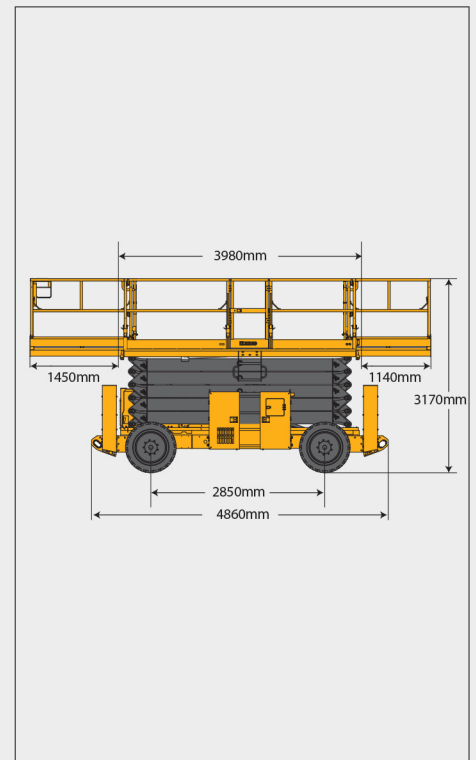
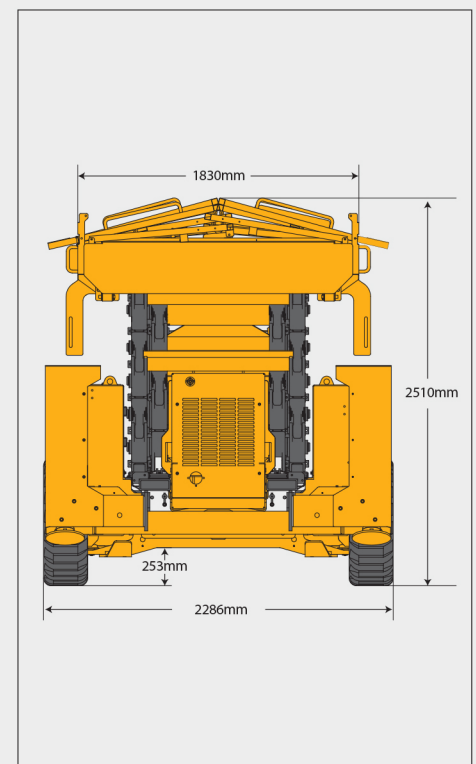

# XG1823RT

**SOLID  
TO SUCCEED**

## Rough Terrain Scissor Lift-Engine Powered

Item	Metric
<b>Dimension</b>	
Overall length (without ladder/outriggers)	4860mm(-)
Overall width	2286mm
Overall height (platform folded)	3170(2510)mm
Platform length	3980mm
Platform width	1830mm
Subplatform extension length	1450mm/1140mm
Guardrail height	1100mm
Toeboard height	150mm
Outrigger span (side to side/front and rear)	1995mm/4280mm
Wheelbase	2850mm
Min. ground clearance	253mm(-)
<b>Performance</b>	
Max. working height	18.1m
Max. platform height	16.1m
Min. platform height	2m
Max. driving height	3.6m(Standard) / 9.1m(optional)
Rated load	680kg
Extended platform load	230kg
Max. number of occupants (indoor/outdoor)	4/4
Max. driving speed in stowed state	6.1km/h
Max. driving speed in working state	0km/h(Standard) / 1.1km/h(optional)
Max. slope grade	40%
Min. turning radius (inside)	2.5m
Min. turning radius (outside)	5.6m
Work platform raising time	55s
Work platform lowering time	55s
Max. working slope (side to side/front and rear)	2°/3°
Outrigger leveling angle (side to side/front and rear)	/
<b>Power source</b>	
Engine model	Kubota V2403
Engine power/rpm	36.8kW/(2700r/min)
Max. engine torque	158N·m
Hydraulic tank capacity	115L
Fuel tank capacity	115L
<b>Tire</b>	
Tire size	835mm×290mm
Tire ground pressure	13.3kg/cm <sup>2</sup>
Driving wheels	4
Braking wheels	4
Steering wheels	2
<b>Weight</b>	
Total weight	8000kg

**Stowed**

**Trans**



**SOLID**  
TO SUCCEED



# ROUGH TERRAIN SCISSOR LIFT XG1823RT

Comply with CE

## Standard configuration

- Foldable guardrail
- Platform self-locking door
- Dual slide-out platform extension deck
- Anti-slipping metal platform
- Boom safety maintenance support
- Pull-out engine tray
- Standard Forklift pocket for transport
- Lanyard connection point
- Fixing and lifting points
- 4-wheel drive
- Front-wheel steering
- Movement alarm
- Strobe light
- Electric horn
- Emergency stop button
- Fuel level display
- Full proportion travel and lift control
- High-altitude automatic limit travel protection
- Limiting position deceleration and limit protection
- Outrigger leveling system
- Hydraulic oil cooling system
- Tilt protection system
- Auto brake system
- Fault diagnosis system
- Emergency lowering system
- Leveling outrigger support detection system
- Engine condition monitoring and start protection system
- Weighing alarm system
- Axle oscillation system



Working height  
18.1 meters



Lift capacity  
680Kg



Diesel  
power



## Optional configuration

- High-altitude low speed travel
- Chassis protective fence
- Non-marking rubber tire
- Platform anti-collision
- Platform external power supply



**MG** PLANT & MACHINERY  
EXPORTS & SALES LTD

**TEL: 094 92 51209**



**MG** PLANT & MACHINERY  
EXPORTS & SALES LTD

**CALL SALES**

**094 9251209**

**087 2466111**

**087 6685466**