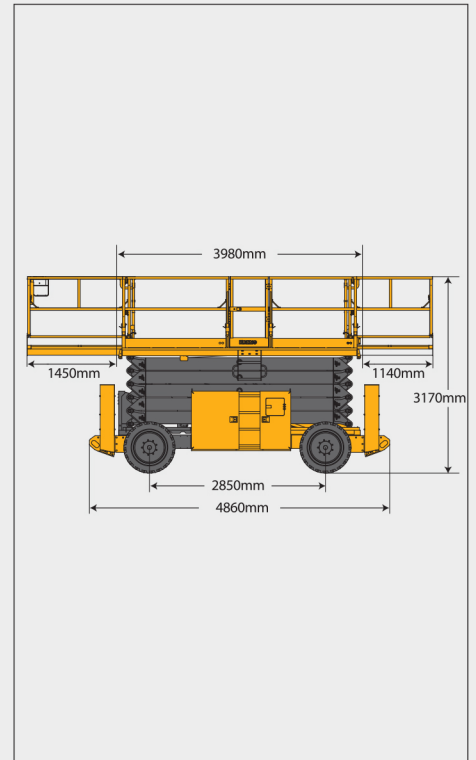
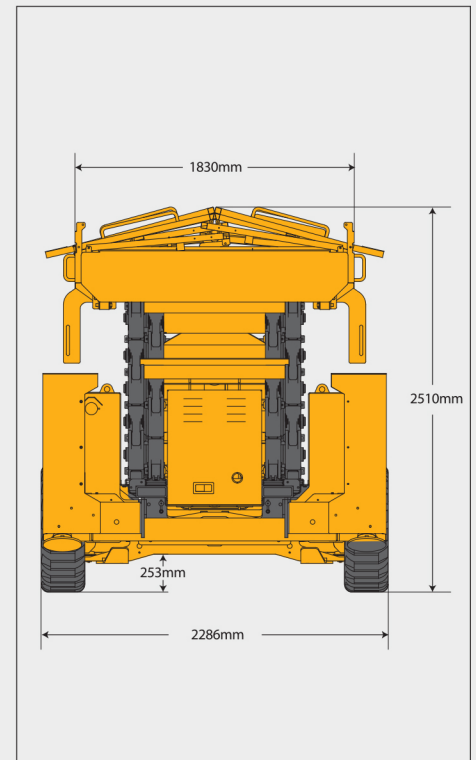

XG1823ERT

Rough Terrain Scissor Lift-Electric

Item	Metric
Dimension	
Overall length (without ladder/outriggers)	4860mm(—)
Overall width	2286mm
Overall height (platform folded)	3170(2510)mm
Platform length	3980mm
Platform width	1830mm
Subplatform extension length	1450mm/1140mm
Guardrail height	1100mm
Toeboard height	150mm
Outrigger span (side to side/front and rear)	1995mm/4280mm
Wheelbase	2850mm
Min. ground clearance (pothole protection deployed/undeployed)	253mm(—)
Performance	
Max. working height	18.1m
Max. platform height	16.1m
Min. platform height	2m
Max. driving height	3.6m(Standard) 9.1m(optional)
Rated load	700kg
Subplatform rated load	230kg
Max. number of occupants (indoor/outdoor)	4/4
Max. driving speed (stowed)	5.1km/h
Max. driving speed (raised)	0km/h(Standard) 1.1km/h(optional)
Max. gradeability	40%
Min. turning radius (inside)	2.5m
Min. turning radius (outside)	5.6m
Platform raising time	75s
Platform lowering time	55s
Max. working slope (side to side/front and rear)	2°/3°
Outrigger leveling angle (side to side/front and rear)	/
Power source	
Battery voltage	48V
Battery capacity (5HR)	480Ah
Battery charger	48V/35A
Traveling motor	3.3kW/32V
Lifting motor	12kW/31V
Hydraulic tank capacity	100L
Tire	
Tire size	835mm×290mm
Tire ground pressure	13.3kg/cm ²
Driving wheels	4
Braking wheels	4
Steering wheels	2
Weight	
Total weight	8380kg

Stowed

Trans

ROUGH TERRAIN SCISSOR LIFT XG1823ERT

Comply with CE

Standard configuration

- Foldable guardrail
- Platform self-locking door
- Dual slide-out platform extension deck
- Anti-slipping metal platform
- Boom safety maintenance support
- Pull-out engine tray
- Standard Forklift pocket for transport
- Lanyard connection point
- Fixing and lifting points
- 4-wheel drive
- Front-wheel steering
- Movement alarm
- Strobe light
- Electric horn
- Emergency stop button
- Battery power display
- Full proportion travel and lift control
- High-altitude automatic limit travel protection
- Limiting position deceleration and limit protection
- Outrigger leveling system
- Tilt protection system
- Charging protection system
- Auto brake system
- Fault diagnosis system
- Emergency lowering system
- Leveling outrigger support detection system
- Wheel-side traveling motor state monitoring and overtemperature stall protection system
- Weighing alarm system
- Axle oscillation system



Working height
18.1 meters



Lift capacity
700Kg



Electric
power



Optional configuration

- High-altitude low speed travel
- Chassis protective fence
- Non-marking rubber tire
- Platform anti-collision





MG PLANT & MACHINERY
EXPORTS & SALES LTD

CALL SALES

094 9251209

087 2466111

087 6685466